



نهال سان

ایده هایی برای زندگی معاصر



NAHALSAN



ideas for contemporary life

Catalogue

Browse Our Products



Stackable

Collapsible/
Foldable

Easy to
Assemble



Rain resistant

UV Resistant

User Count

Legend

Economical Models



Semi-matt black Reddish purple Brown

Luxury models (other colors)

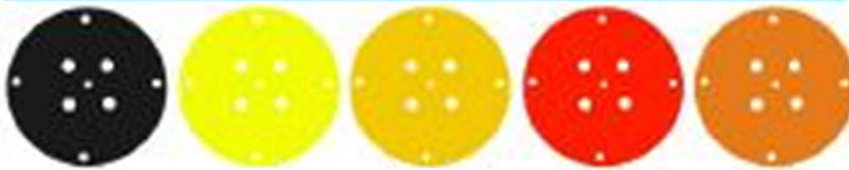

Black (glossy, matte,
super matte) 9006

Yellow
1021

Caterpillar
yellow
1028

Red
3020

Orange
2008



Celeste
4201

Navy blue
5012

Cobalt blue
5005

Dark green
6029

Green
6018



Light pink
230

Light gray
7038

Dark coral
7049

Other coatings



Vinyl Iron metal
236

Chrome coating

Golden coating



Colors and Coatings

NAHALSAN engineering company began its activity by producing automobile parts in 1977. After the gradual increase in our production capacity and the expansion of factory area to 15,000 and later 12,000 square meters of indoors space, the company focused on improving the quality and quantity of its products by establishing design, engineering, R&D, and quality control departments.

The idea of designing and manufacturing different types of metal stools and chairs was initiated in 2012 and after improving product diversity and quality, it was registered under the brand *Imen Hami Farasan* in 2016 and introduced to the market.

In 2015 this brand acquired the ISO9001 and CE standards. In 2019, this brand acquired IRAN STANDARD.

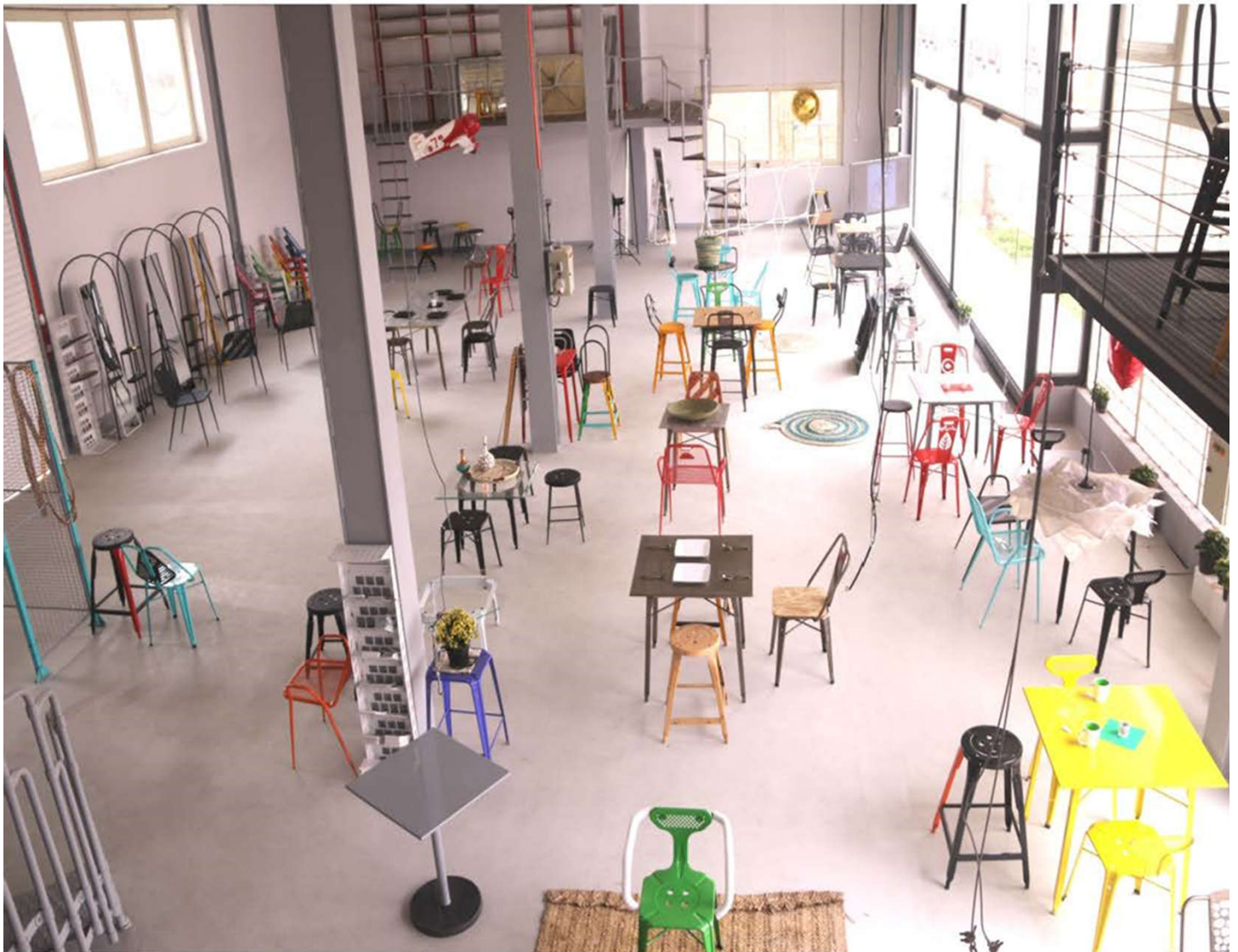

With more than 30 years of valuable experience in industrial manufacturing, NAHALSAN-PARAX Group began manufacturing and designing contemporary life necessities in 2012.

Our goals are creative and unique design tailored to the taste of the contemporary generation, leading to customer satisfaction and their enjoyment of our products.

Our deep commitment to designing and producing quality products has led to creation of durable, unique, standard, and ergonomic products.

The use of high-quality raw materials has led to excellent lightweight yet sturdy products.

Manufacturing products with a diverse color pallet, to meet tastes of our client, in different sizes, and at suitable prices with a reliable warranty are some of the professional codes of PARAX.

NAHALSAN products consist of various types of stools, chairs, and desks/tables in different models.



Simple

Beautiful

Chic

Appealing

Modern



Product List

Assembled stool
p. 16



Double-rest stool
p. 14



Single-rest stool
p. 10



Simple stool
p. 8



Navid
p. 28



Bitá
p. 24



Karyar
p. 22



Pelikan stool
p. 20



Single-foot table
p. 42



PARAX
table
p. 38



Bar table
& bench
p. 36



Nasim
p. 32



Barbecue maker
p. 54



Mirror
p. 52



Peripherals
p. 48



Specials
p. 44



NEW
Assembled Pelikan
p. 59



NEW
Karyar family
p. 58



NEW
Foldable chair
p. 57



جدید
NEW Golyar
p. 56



جدید
NEW Lights
p. 61



جدید
NEW Side tables, Flower tables
p. 62



جدید
NEW Foldable table
p. 61



جدید
NEW Classic tables
p. 60



Stairs
p. 76

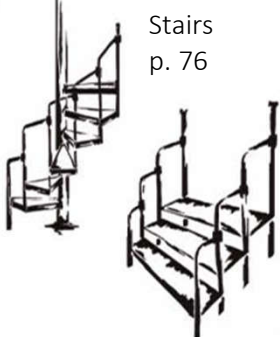

Scaffold tables
p. 74



Space frame structures
p. 71



New, diverse products to be released soon



Weight (kg)	Material	Product code	Width (cm)	Height (cm) ارتفاع
3.9	Steel	AC01A00113ZZ	34	35
1.1	Aluminum	AC01A00213ZZ		
4.1	Steel	AC01A00114ZZ	36	40
1.25	Aluminum	AC01A00214ZZ		
4.3	Steel	AC01A00115ZZ	38	50
1.4	Aluminum	AC01A00215ZZ		
4.5	Steel	AC01A00116ZZ	41	60
1.55	Aluminum	AC01A00216ZZ		
5	Steel	AC01A00117ZZ	44	70
--	Aluminum	AC01A00217ZZ		
5.2	Steel	AC01A00118ZZ	47	80
--	Aluminum	AC01A00218ZZ		
5.8	Steel	AC01A00119ZZ	50	90
--	Aluminum	AC01A00219ZZ		



Seat width: 32 cm

The product can be custom-made in other heights

نهال سان

ایده هایی برای زندگی معاصر

NAHALSAN

ideas for contemporary life



نهال سان

ایده هایی برای زندگی معاصر

NAHALSAN

ideas for contemporary life

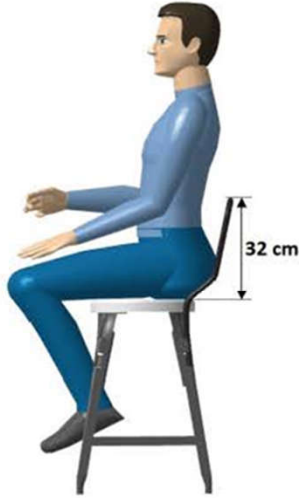

Single-rest stool



Single-rest stool



Weight (kg)	Material	Product code	Width (cm)	Height (cm)
5	Steel	AC01A00125ZZ	38	50
2.1	Aluminum	AC01A00225ZZ		
5.15	Steel	AC01A00126ZZ	41	60
2.25	Aluminum	AC01A00226ZZ		
5.65	Steel	AC01A00127ZZ	44	70
5.9	Steel	AC01A00128ZZ	47	80
6.45	Steel	AC01A00129ZZ	50	90

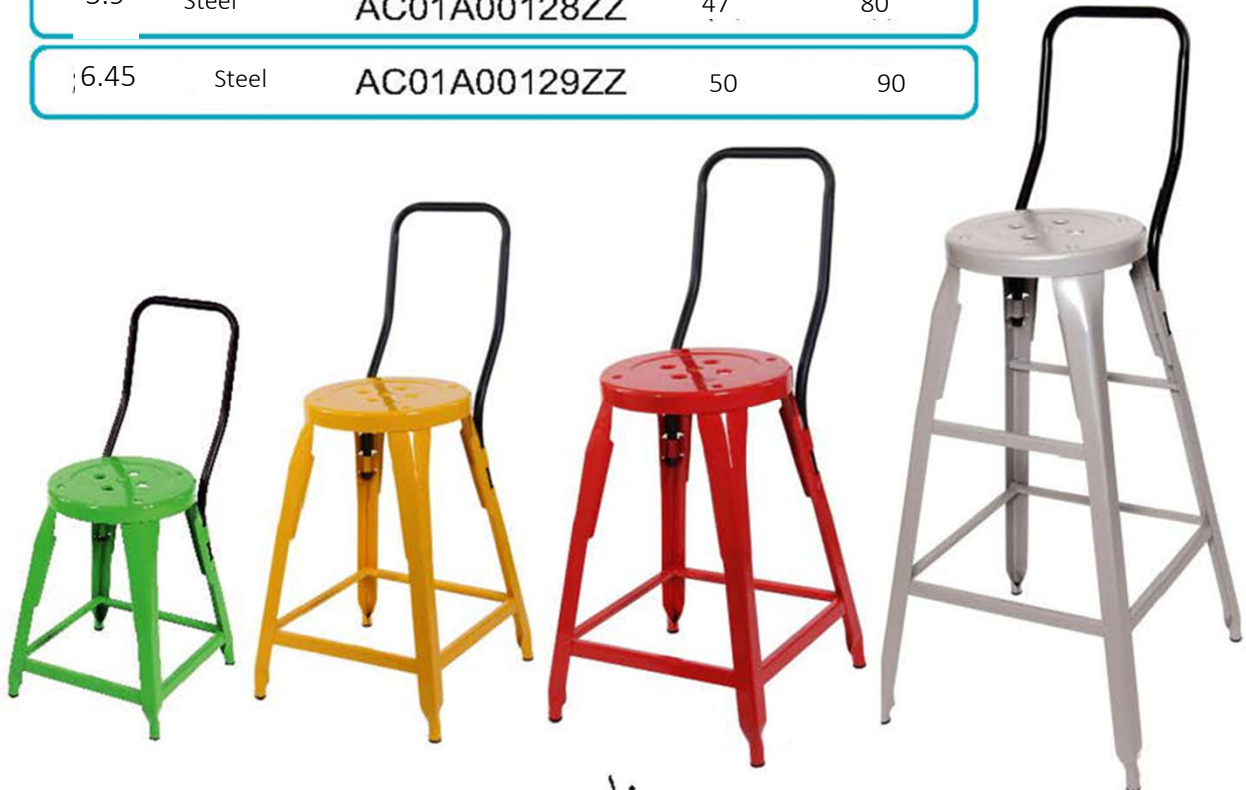

نهال سان

ایده هایی برای زندگی معاصر

NAHALSAN

ideas for contemporary life









Double-rest stool

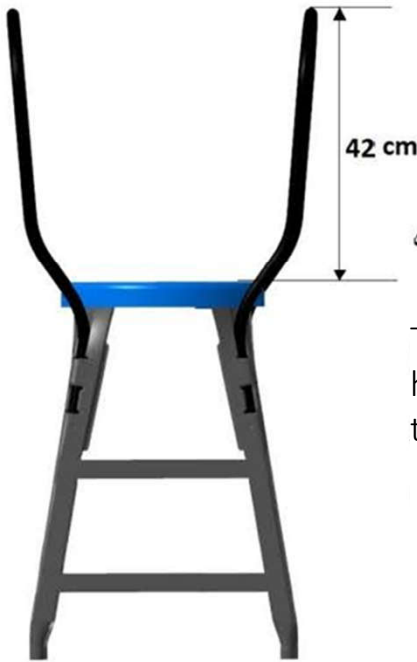

42 cm

Karsaz model is a design revolution and an essential product suited to our living requirements. It offers an innovative design and multipurpose functions making it unique and unmatched in the world.

The product increases your access and dominance over hard-to-reach areas and shelves while you can be sure that it protects your safety and productivity.



Assembled 60 cm



Simple 50 cm



Weight (kg)	Material	Product code	Width (cm)	Height (cm)
5.6	Steel	AC01A00135ZZ	38	50
2.75	Aluminum	AC01A00235ZZ		
5.8	Steel	AC01A00136ZZ	41	60
2.9	Aluminum	AC01A00236ZZ		
6.3	Steel	AC01A00137ZZ	44	70
6.55	Steel	AC01A00138ZZ	47	80
7.1	Steel	AC01A00139ZZ	50	90



Assembled stool



-height: 60cm

With two rests

Packaged weight: 6 kg

Package dimensions: 12x39x89 cm

The foot and seat are made of aluminum. Other parts are of steel.

All parts are in black. Only the seat color is different.

ست

(This product is available in custom size, color, and models).



(تولید محصول)

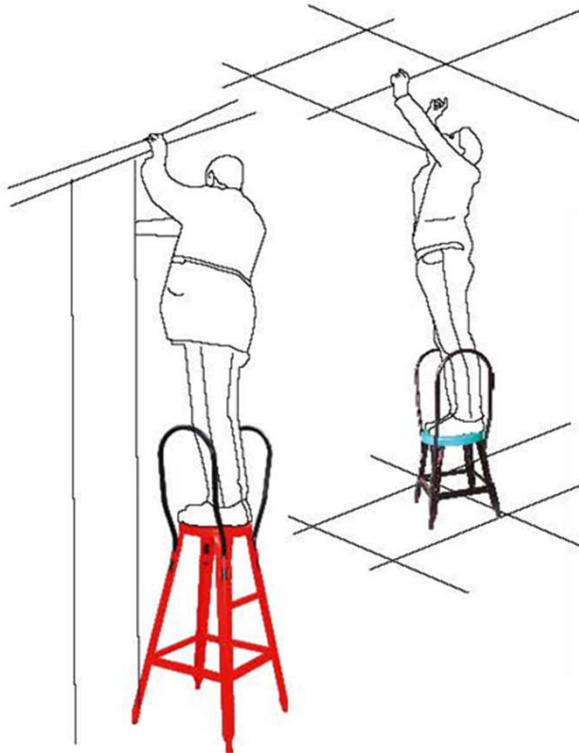

Pros and uses

- Quick assembly
- Precise design and manufacture
- Easy transport
- Excellent raw materials
- Innovative fittings
- No need for screws and nuts
- No need for special tools
- Suitable packaging
- Suitable weight
- Sturdy

Package contents

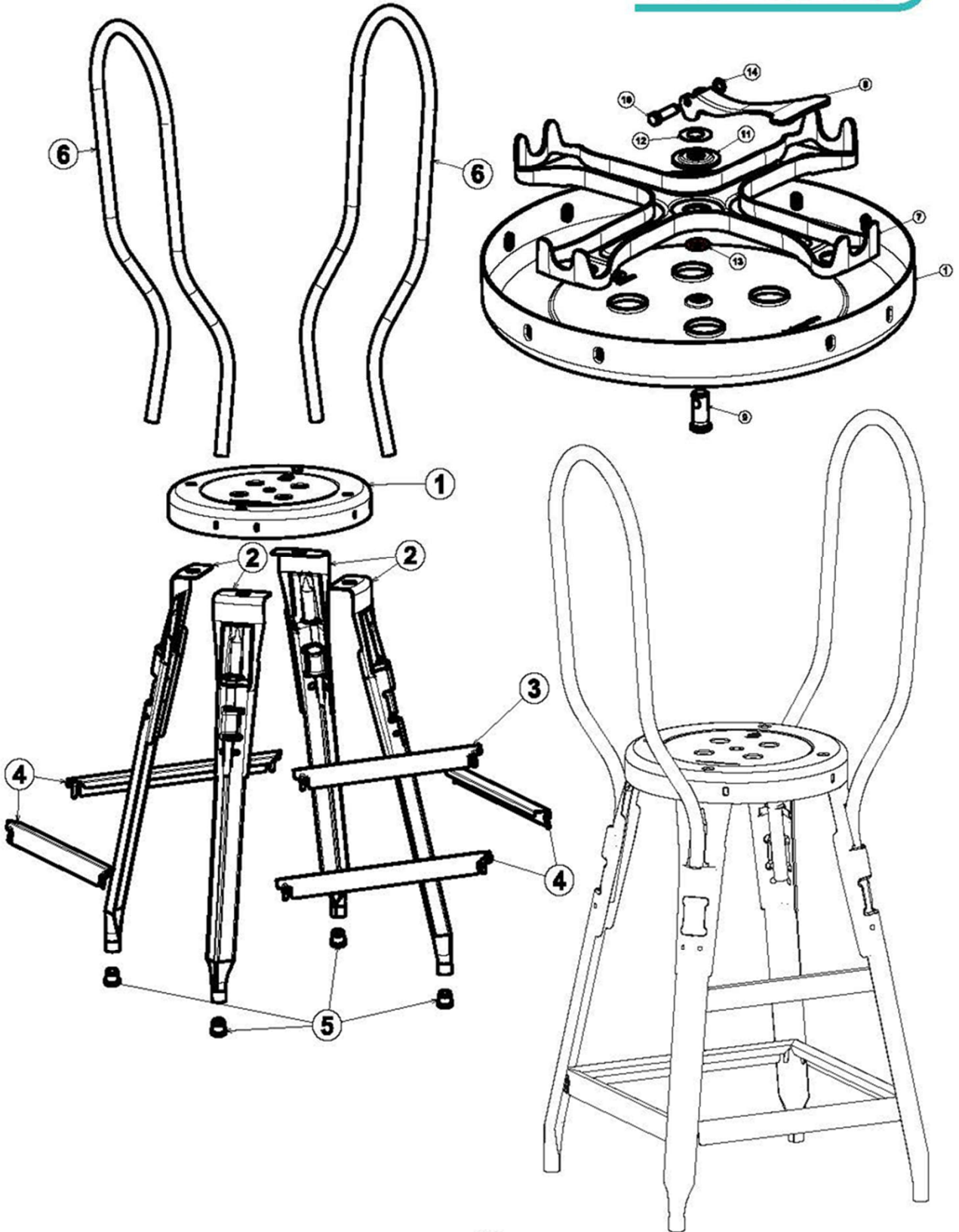

Assembly guide

دستور العمل مونتاژ

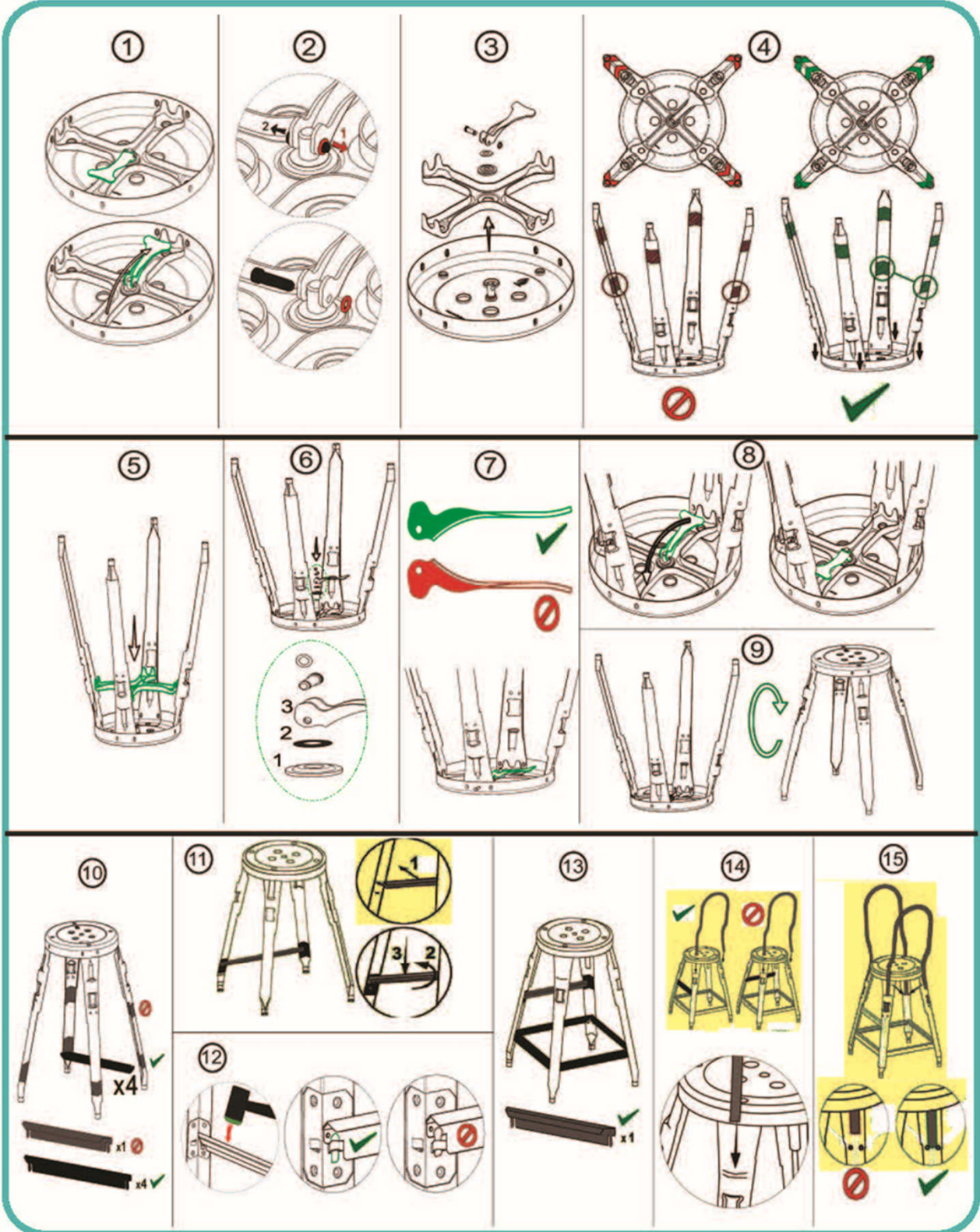

نهالسان

ایده هایی برای زندگی معاصر

NAHALSAN

ideas for contemporary life



نهال سان

ایده هایی برای زندگی معاصر

NAHALSAN

ideas for contemporary life

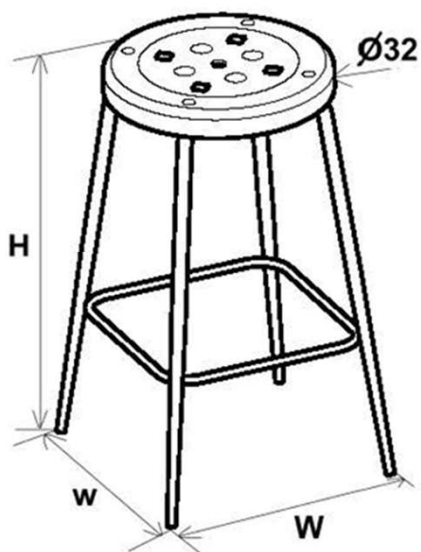

Weight (kg)	Product code	Width (cm)	Height (cm)	Seat
3	AP01A00105ZZ	35	50	Metal seat
3.1	AP01A00106ZZ	37	60	
3.3	AP01A00107ZZ	37	70	
2.8	AP01A00605ZZ	35	50	Wood seat (finger joint)
2.9	AP01A00606ZZ	37	60	
3.1	AP01A00607ZZ	37	70	

نهالسان

ایده هایی برای زندگی معاصر

NAHALSAN

ideas for contemporary life



نهال سان

ایده هایی برای زندگی معاصر

NAHALSAN

ideas for contemporary life



Karyar



Weight (kg)
(کیلوگرم)

5.2

مول

Product
code

AK01A00100ZZ

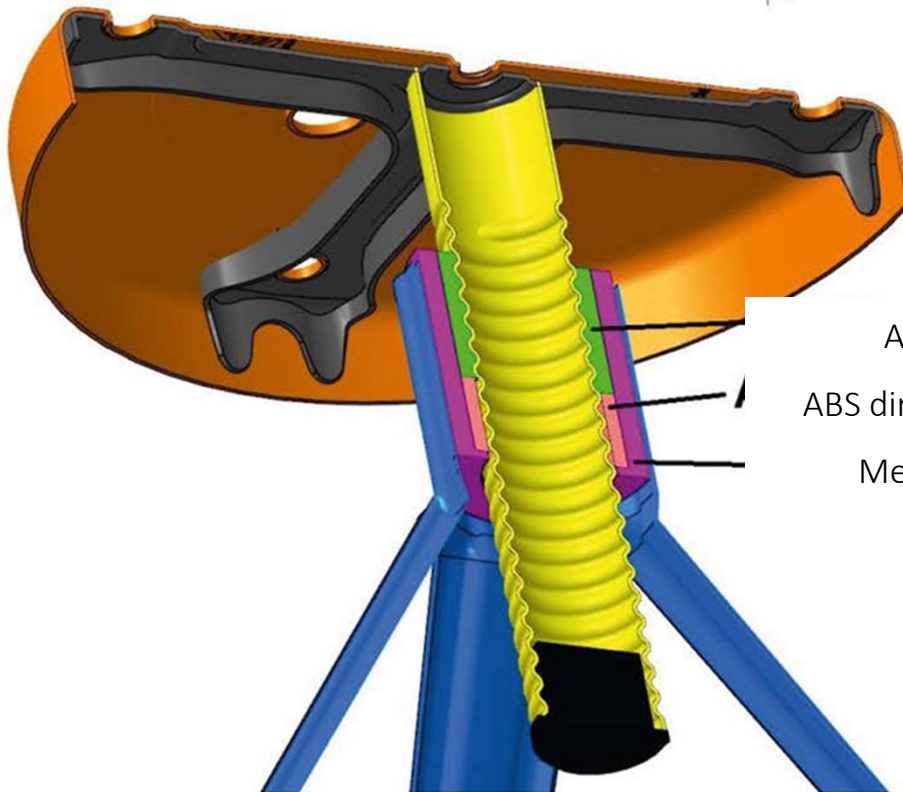
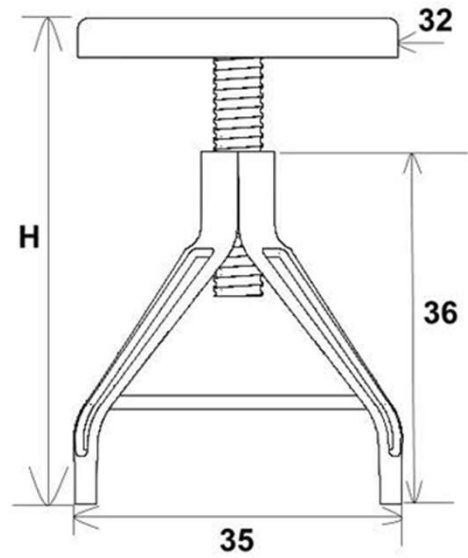

ABS nut

ABS directing bush

Metal bush



Adjustable height
between 40 to 55cm

ارتفاع قابل تنظیم

تا ۵۵ سانتیمتر



Tall (counter side) Karyar



Adjustable height between 60 and
75 cm

نهال سان

ایده هایی برای زندگی معاصر

NAHALSAN

ideas for contemporary life

Bitá (45 cm)



مدل بیتا (۴۵ سانت)

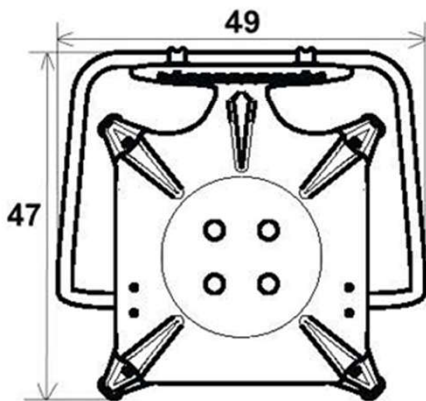
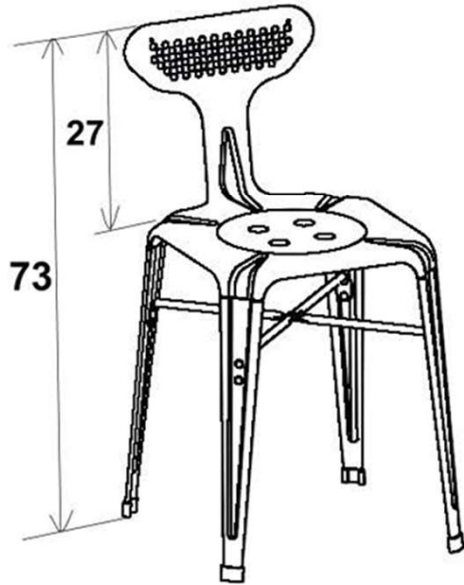
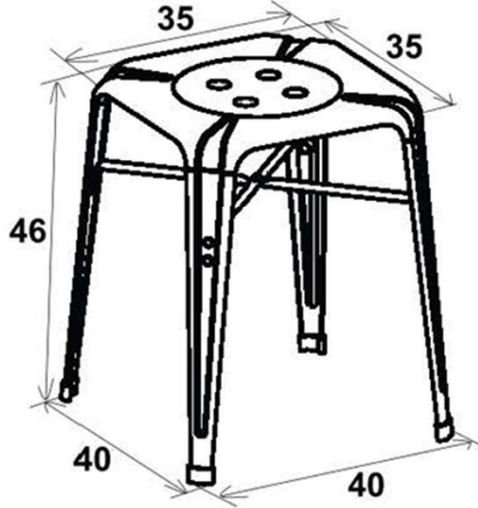

Image	Weight (kg)	Name
 AD01A00111ZZ	4.5	Bitá-simple 
 AD01A00121ZZ	5.2	Bitá-with backrest 
 AD01A00131ZZ	5.8	Bitá-with armrest 

نهال سان

ایده هایی برای زندگی معاصر

NAHALSAN

ideas for contemporary life



نهال سان

ایده هایی برای زندگی معاصر

NAHALSAN

ideas for contemporary life

Bitá (65 cm)



مدل بیتا (۶۵ سانت)

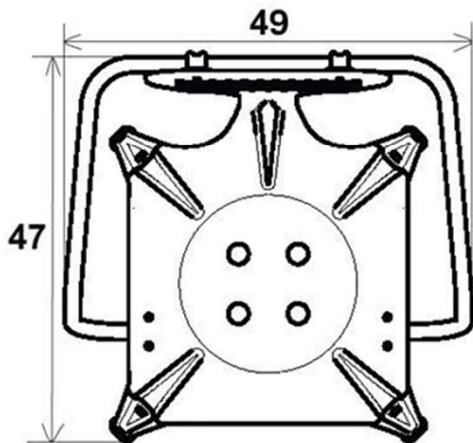
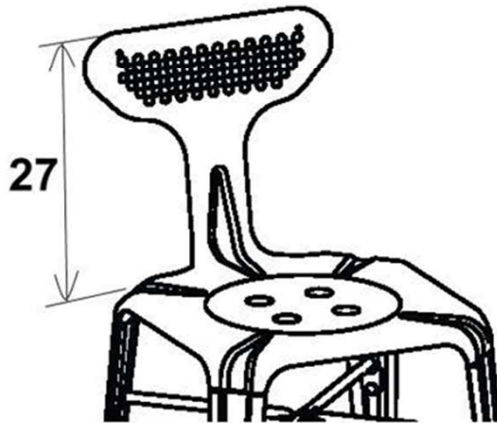
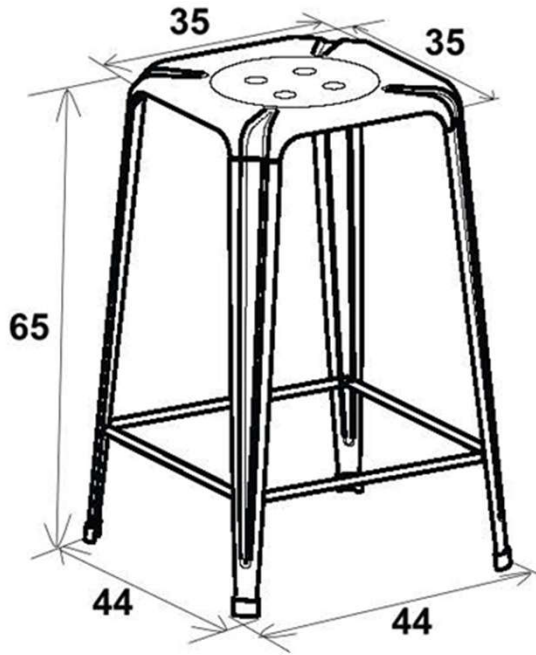

Image	وزن Weight (kg) (کیلوگرم)	نام Name
-------	---------------------------------	-------------



AD01A00112ZZ

5.5

بیتا-ساده
Bitá-simple
ساده



AD01A00122ZZ

6.2

بیتا-
with
backrest



AD01A00132ZZ

6.8

بیتا-
with
armrest



نهال سان

ایده هایی برای زندگی معاصر

NAHALSAN

ideas for contemporary life



نهال سان

ایده هایی برای زندگی معاصر

NAHALSAN

ideas for contemporary life

Navid (45 cm)

مدل نوید (۴۵ سانت)

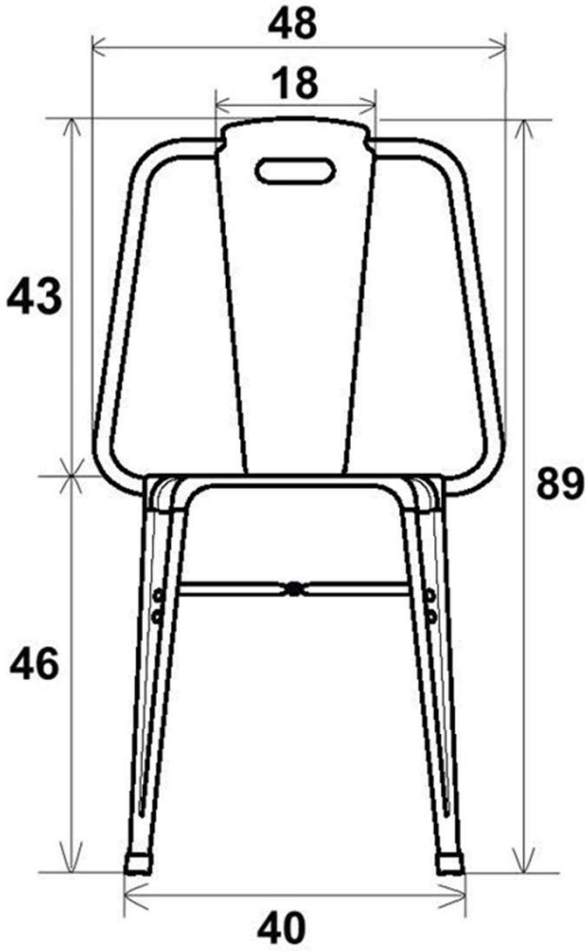

Image	Weight (kg)	Code	Backrest type	No.
	5.9	AE01A00111ZZ	Simple	1
	5.75	AE01A00121ZZ	Leaf pattern	2
	5.5	AE01A00131ZZ	Cobblestone pattern	3
	5.6	AE01A00141ZZ	Punched	4
		AE01A00161ZZ	Custom-pattern	5



نهال سان

ایده هایی برای زندگی معاصر

NAHALSAN

ideas for contemporary life



نهال سان

ایده هایی برای زندگی معاصر

NAHALSAN

ideas for contemporary life

Navid (65 cm)



مدل نوید (۶۵ سانت)

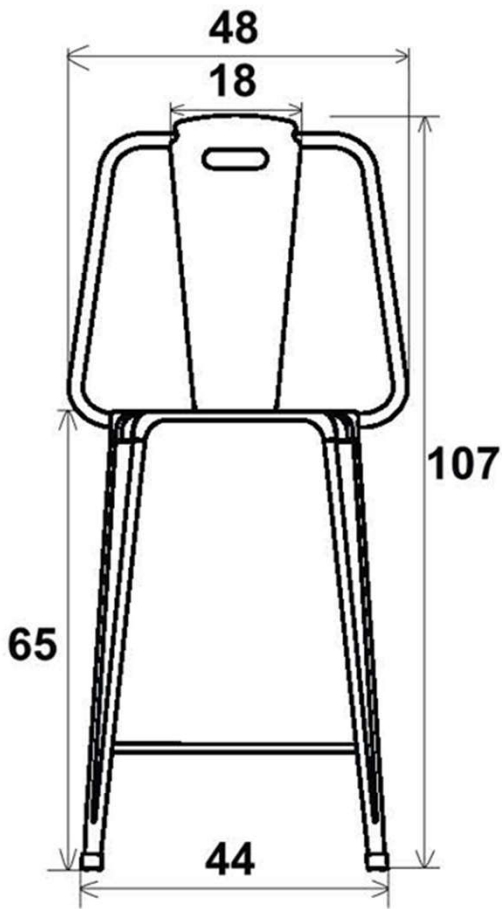

Image	Weight (kg)	Code	Backrest type	No.
	6.6	AE01A00112ZZ	Simple	1
	6.45	AE01A00122ZZ	Leaf pattern	2
	6.2	AE01A00132ZZ	Cobblestone pattern	3
	6.3	AE01A00142ZZ	Punched	4
		AE01A00162ZZ	Custom-pattern	5





نهال سان

ایده هایی برای زندگی معاصر

NAHALSAN

ideas for contemporary life

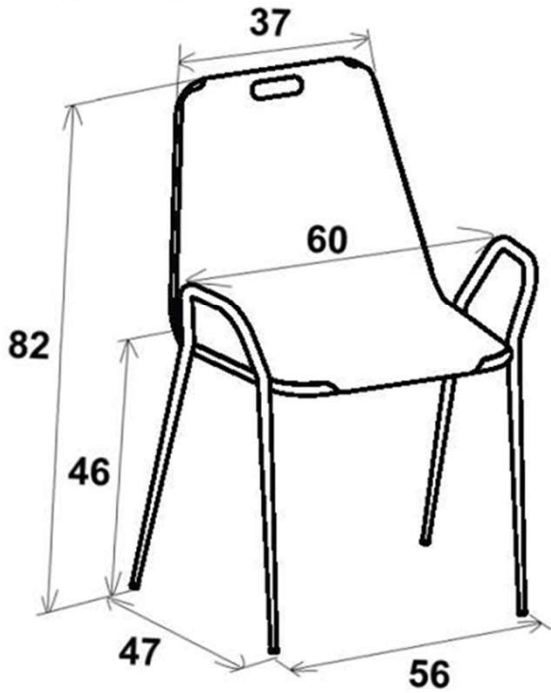

Wt. (kg)	Product code	Seat Model
6.5	AF01A00121ZZ	Simple (calm)
5.6	AF01A00131ZZ	5X (Sport)
4.1	AF01A00111ZZ	Full-punch
		Modern classic



Featuring tall, curved backrest
Suitable for dining table

NEW

نهال سان

ایده هایی برای زندگی معاصر

NAHALSAN

ideas for contemporary life



X5
(Sport)



Simple
(calm)



Modern
classic



Full-
punch

نهالسان

ایده هایی برای زندگی معاصر

NAHALSAN

ideas for contemporary life



نهال سان

ایده هایی برای زندگی معاصر

NAHALSAN

ideas for contemporary life





Image	Wt. (kg)	Product name	No.
		Structure AH01A00122ZZ	1
		Simple metal top AH01A00112ZZ	2
	16.8	Punched metal top AH01A00132ZZ	3
	11.6	Wood top (thermowood) AH01A00742ZZ	4

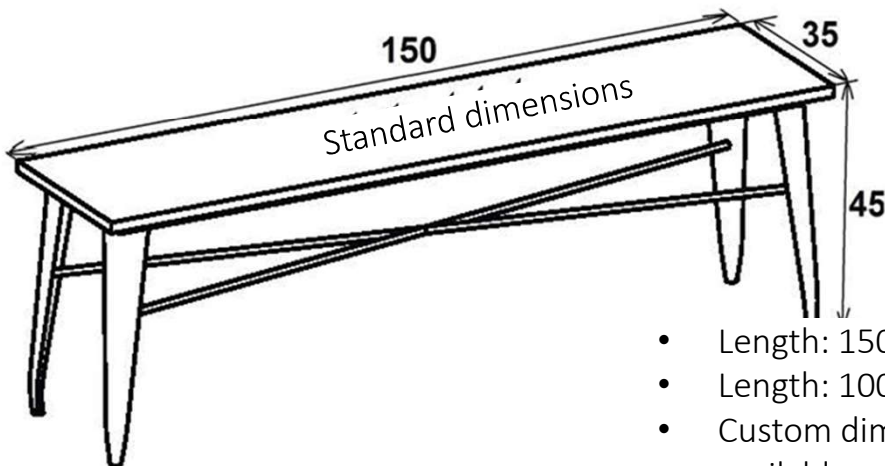

- Length: 150 cm
- Length: 100 cm
- Custom dimensions available



نهال سان

ایده هایی برای زندگی معاصر

NAHALSAN

ideas for contemporary life



Bench (thermowood top)

Height: 90 cm

Dim: 150 x 35 cm

Bar table (thermowood top)



نهال سان

ایده هایی برای زندگی معاصر

NAHALSAN

ideas for contemporary life



Parax Table

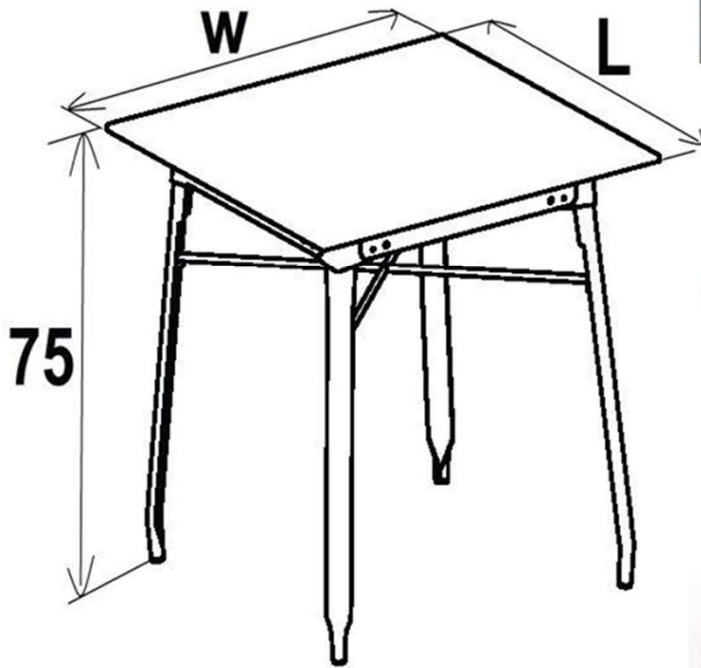

Available in custom dimensions

Natural wood (thermowood)
top







Punched top





Structure



Compatible with
various, custom tops

Image	Wt. (kg)	Top model	Top dimensions
	<p>8.1</p> <p>7.6</p>	<p>Frame (topless)</p> <p>Metal top</p> <p>Punched metal top</p> <p>Wood top (thermowood)</p>	<p>60x60</p> 
			
	<p>14.3'</p> <p>14</p> <p>14.6'</p>	<p>Frame (topless)</p> <p>Metal top</p> <p>Punched metal top</p> <p>Wood top (thermowood)</p>	<p>80 x 80</p> 

80 x 120 	60 x 120 	Top model
AG01A001D1ZZ	AG01A001C1ZZ	Frame (topless)
AG01A00151ZZ	AG01A00141ZZ	Metal top
AQ01A00151ZZ	AQ01A00141ZZ	Punched metal top
AG01A00651ZZ	AG01A00641ZZ	Wood top (thermowood)

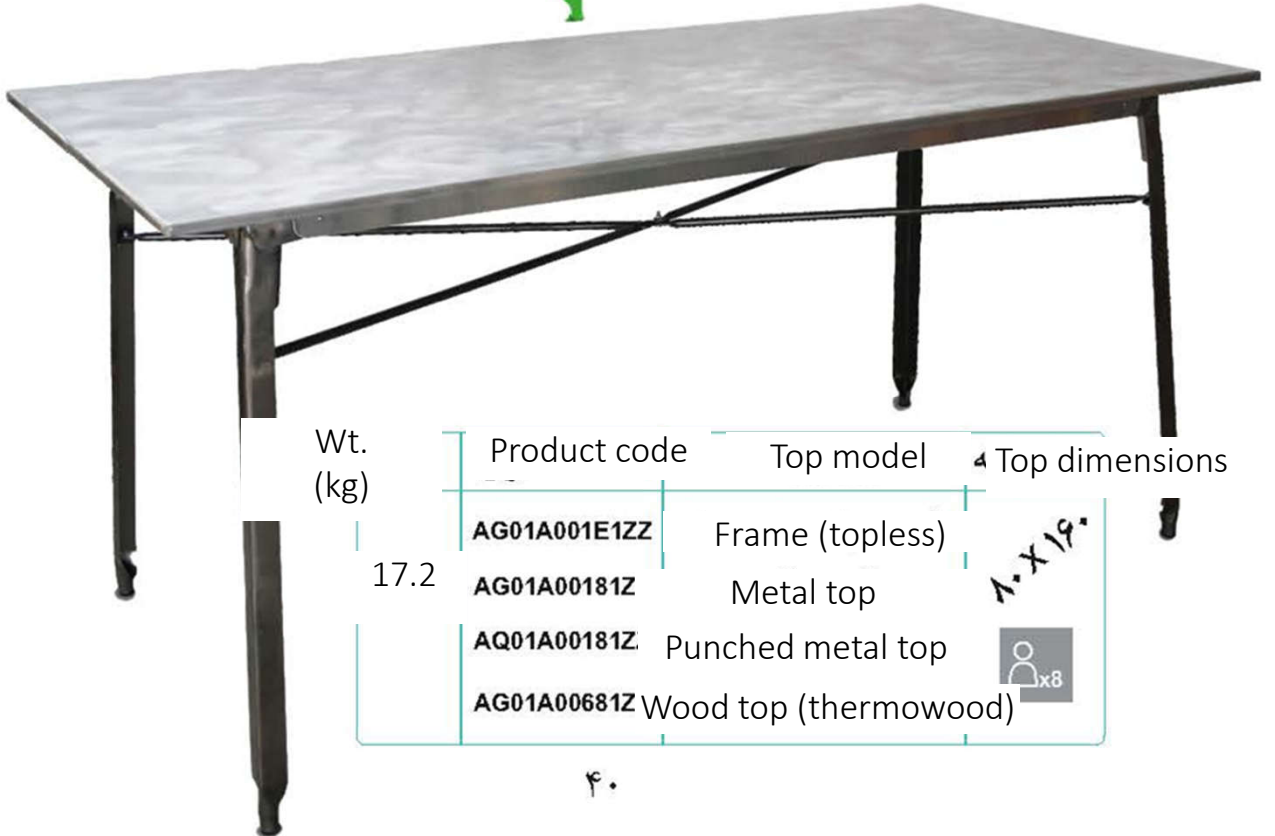

Wt. (kg)	Product code	Top model	Top dimensions
17.2	AG01A001E1ZZ	Frame (topless)	1.0 x 1.9
	AG01A00181Z	Metal top	
	AQ01A00181Z	Punched metal top	
	AG01A00681Z	Wood top (thermowood)	

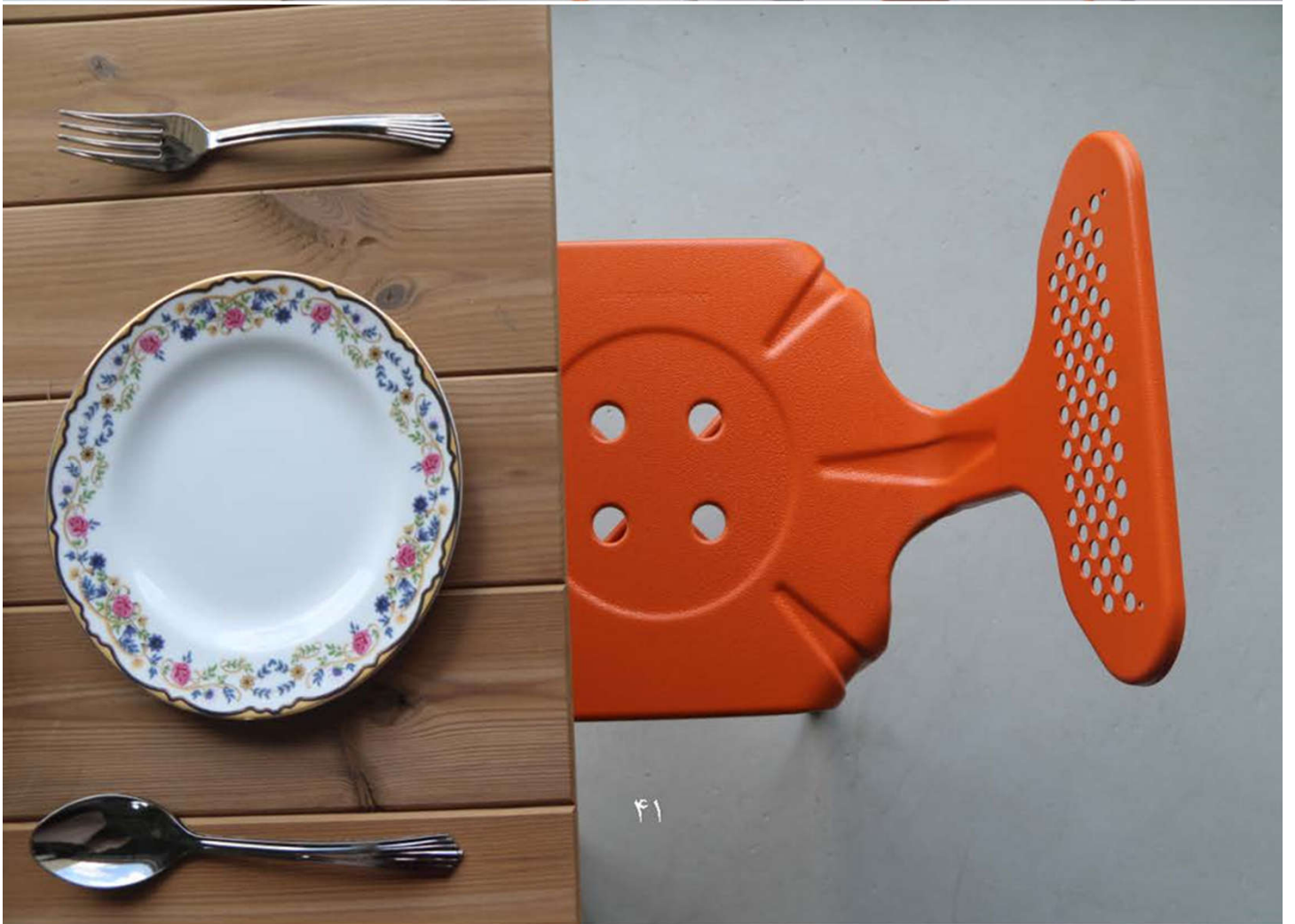

نهال سان

انده هانه، بانه، زندگه، معاصر



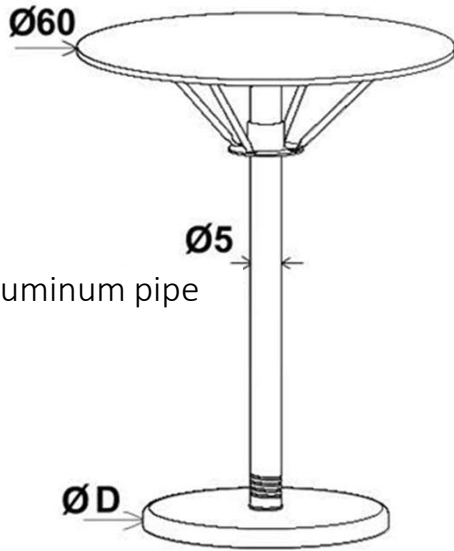

NAHALSAN

ideas for contemporary life



- Aluminum pipe



	Diameter	Product code	Top dimensions	No.
	50	AG01A00621ZZ	Round (Diameter 60)	1
	50		60 x 60	2
	60		70 x 70	3
	60		80 x 80	4

- Available in thermowood top (wooden)
- Chrome coated foot available



Diameter=60



60 x 60



Wood top



70 x 70



80 x 80

نهالسان

ایده هایی برای زندگی معاصر

NAHALSAN

ideas for contemporary life



Golden seat



مدل های ویژه

specials



Windy-Cloudy
(brush and vinyl)



نهال سان

ایده هایی برای زندگی معاصر

NAHALSAN

ideas for contemporary life



Punched models

Patterned models (wood and rocks)



Stools with one-off foot paint



Stools with multicolor foots



Accessories

1. Cushion

Cushion with leather upholstery mountable on products.

Four plastic pins are attached at the cushion's bottom that fit into the seat holes and are fixed by pressing.



AN01A00710ZZ

1.2 kg

Cushion with fabric upholstery



AN01A00910ZZ

1.3 kg

نهالسان

ایده هایی برای زندگی معاصر

NAHALSAN

ideas for contemporary life



2. Rests

Simple rest



Curved rest



3. Backrests

Foam tube backrest



Structure (metal) backrest



AT01A00700ZZ
Foam backrest



نهال سان

ایده هایی برای زندگی معاصر

NAHALSAN

ideas for contemporary life



نهال سان

ایده هایی برای زندگی معاصر

NAHALSAN

ideas for contemporary life

Featuring clothes hangers on
the back side



Mirror with Hangers

12 kg

AN01A00100ZZ

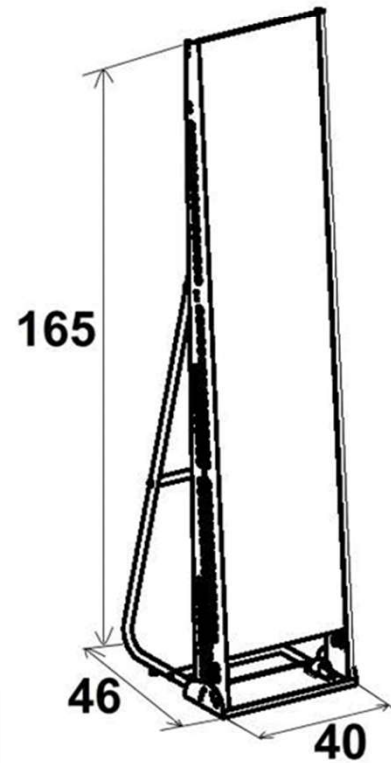
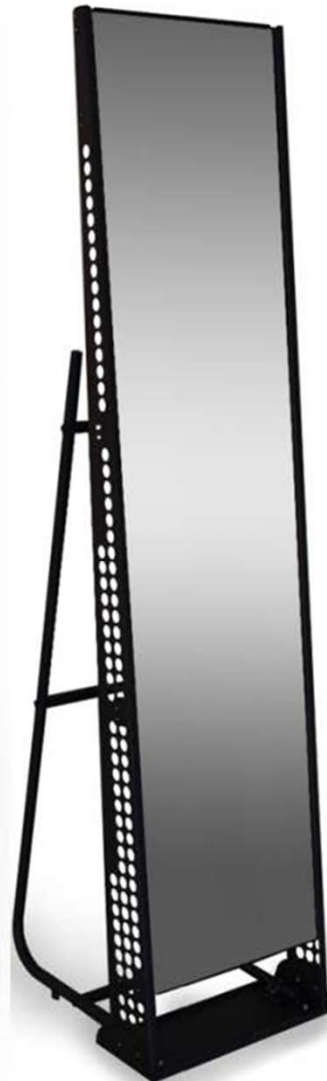

نهال سان

ایده هایی برای زندگی معاصر

NAHALSAN

ideas for contemporary life



Mirror Console
Table





Barbecues Grill

<p>15 33 56 11</p>	<p>4.4 kg</p>	<p>Simple barbecue grill: Grill; Coal tray; Pincer and ladle</p> <p>Product code: AB01A00120ZZ</p>
<p>69 45 48</p>	<p>7.3 kg</p>	<p>Barbecue grill with table: Grill; Table; Coal tray; Pincer and ladle</p> <p>Product code: AB01A00110ZZ</p>
<p>74 23 53</p> <p>Exported model BBQ casing</p>	<p>8.9 kg</p>	<p>Barbecue grill (exported model): Barbecue grill with security lock; Beautifully-designed table; Simple to carry; Coal tray; Pincer and ladle; Stake griller; Plastic carrying case for easy keeping</p> <p>Product code: AB01A00100ZZ</p>

Open

Instructions

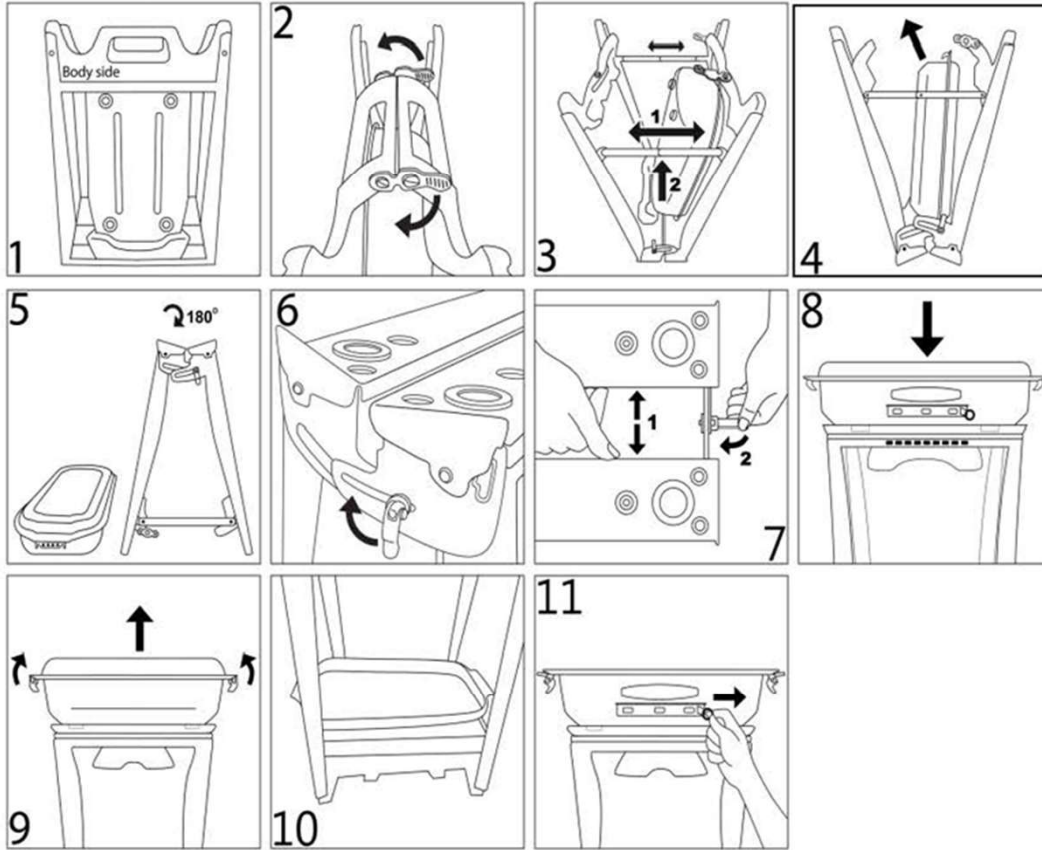

Closed

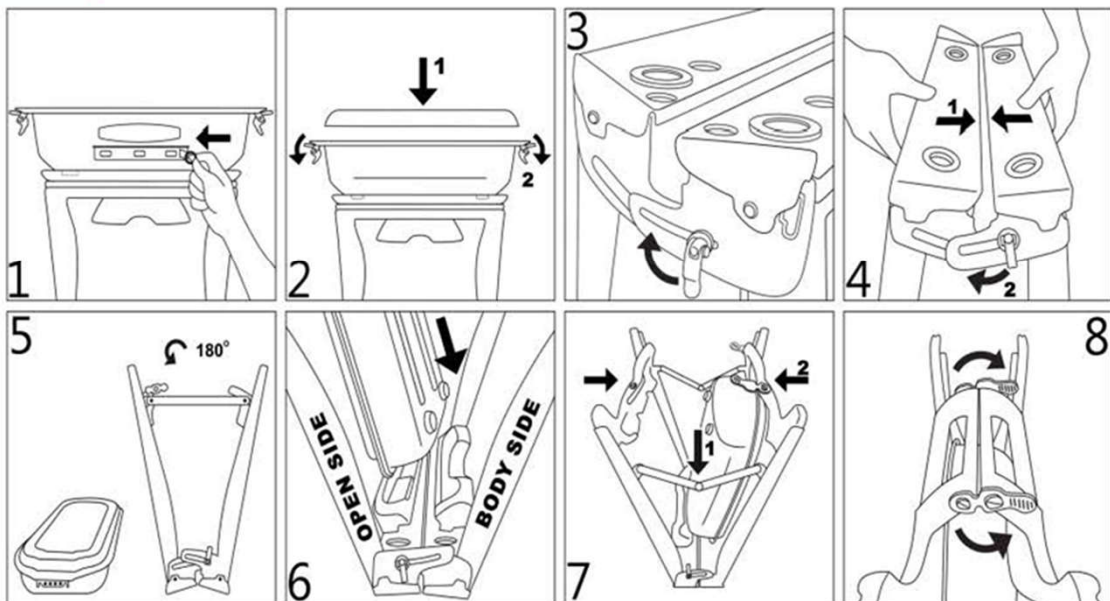

New and Improving Products

Golyar



- Light and sturdy
- Easy to carry
- Detachable bag
- Versatile
- Available in 35 and 50 cm heights



نهال سان

ایده هایی برای زندگی معاصر

NAHALSAN

ideas for contemporary life

Foldable Chair



نهال سان

ایده هایی برای زندگی معاصر

NAHALSAN

ideas for contemporary life

Karyar with backrest



Short (Mother) Karyar



Height adjustable
20 to 30 cm

نهال سان

ایده هایی برای زندگی معاصر

NAHALSAN
ideas for contemporary life

Pelikan (Assembled Model)



نهالسان

ایده هایی برای زندگی معاصر

NAHALSAN

ideas for contemporary life

Classic table



- Chic and stylish
- Available in two different heights as the dining or side table



نهال سان

ایده هایی برای زندگی معاصر

NAHALSAN

ideas for contemporary life

Foldable Table



Tables and Side Tables

Golmiz Model
(Flower Table)

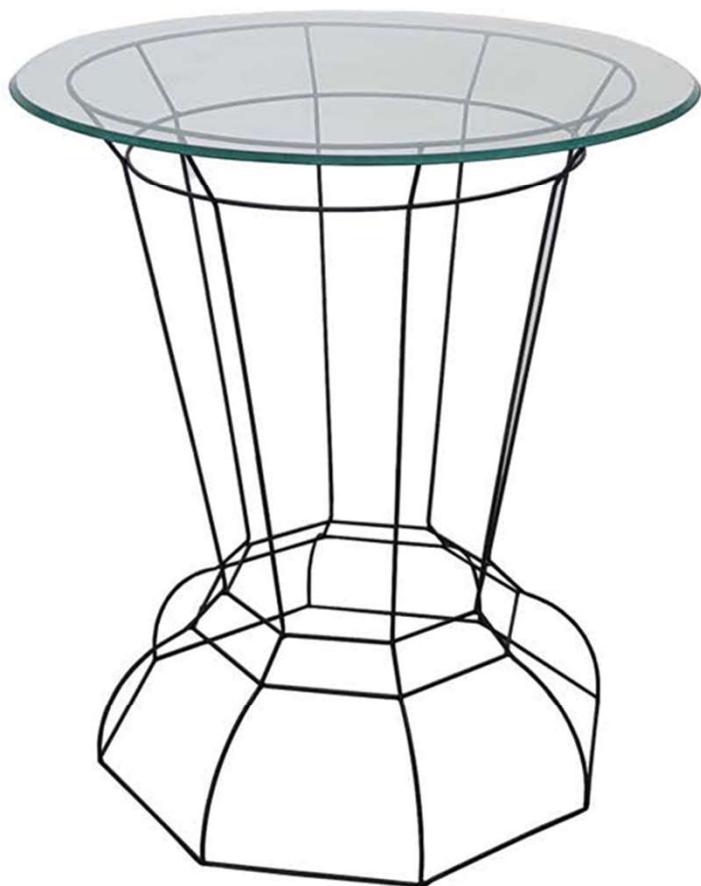

Lamps and Lighting Fixtures



Models under Developing

Bench with backrest

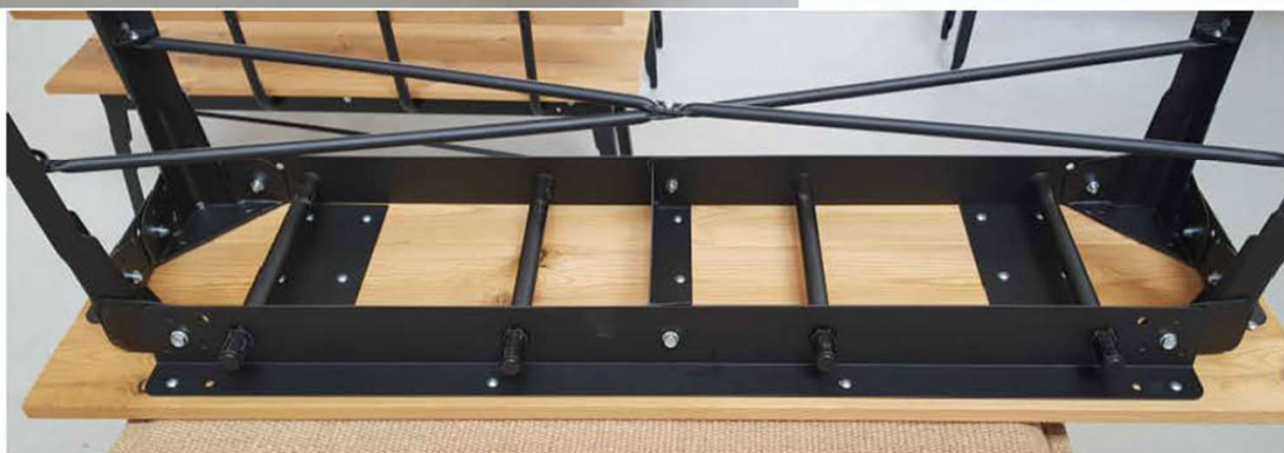

نهال سان

ایده هایی برای زندگی معاصر

NAHALSAN

ideas for contemporary life

New Beds and Benches

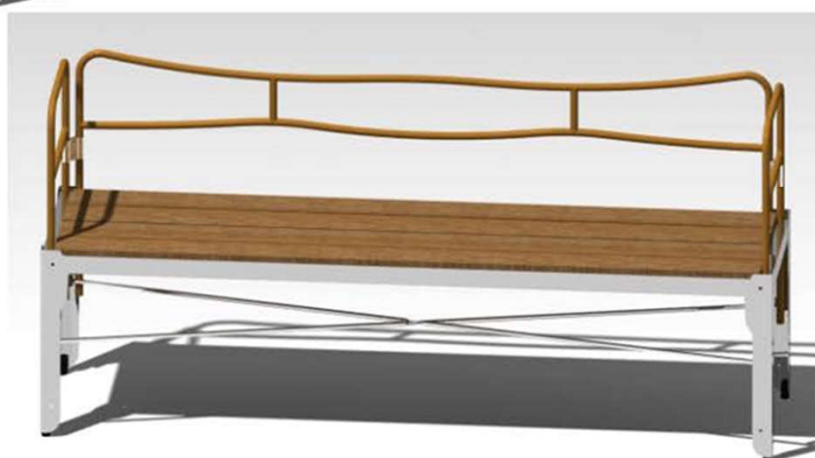

Models under Development

Firewood Barbecue Maker



نهال سان

ایده هایی برای زندگی معاصر

NAHALSAN
ideas for contemporary life



Quality Control (QC)

NAHALSAN strives to produce reliable, quality Iranian products by developing the necessary design, production, and quality control infrastructure aiming for customer satisfaction. Accordingly, a well-equipped QC lab was established in the factory that makes it possible to conduct all necessary tests on site.



Mechanical testing device (for testing the strength and stability of products)

نهال سان

ایده هایی برای زندگی معاصر

NAHALSAN

ideas for contemporary life



According to the 9184 standard, the load tests in horizontal and vertical axes, off-center point, and the drop tests were conducted on the stool. The following table presents the results.

Horizontal and vertical loading test on the stool (Articles 4-7, standard 9184).						
Test Index	Unit	35cm	50cm	60cm	70cm	90cm
FO	kg	20	20	20	20	20
FN	kg	600	600	600	600	600
a	mm	60	60	60	60	60
h	mm	350	500	600	700	900
FC	kg	122.9	72	60	51.42	60
Result		stable	stable	stable	stable	stable

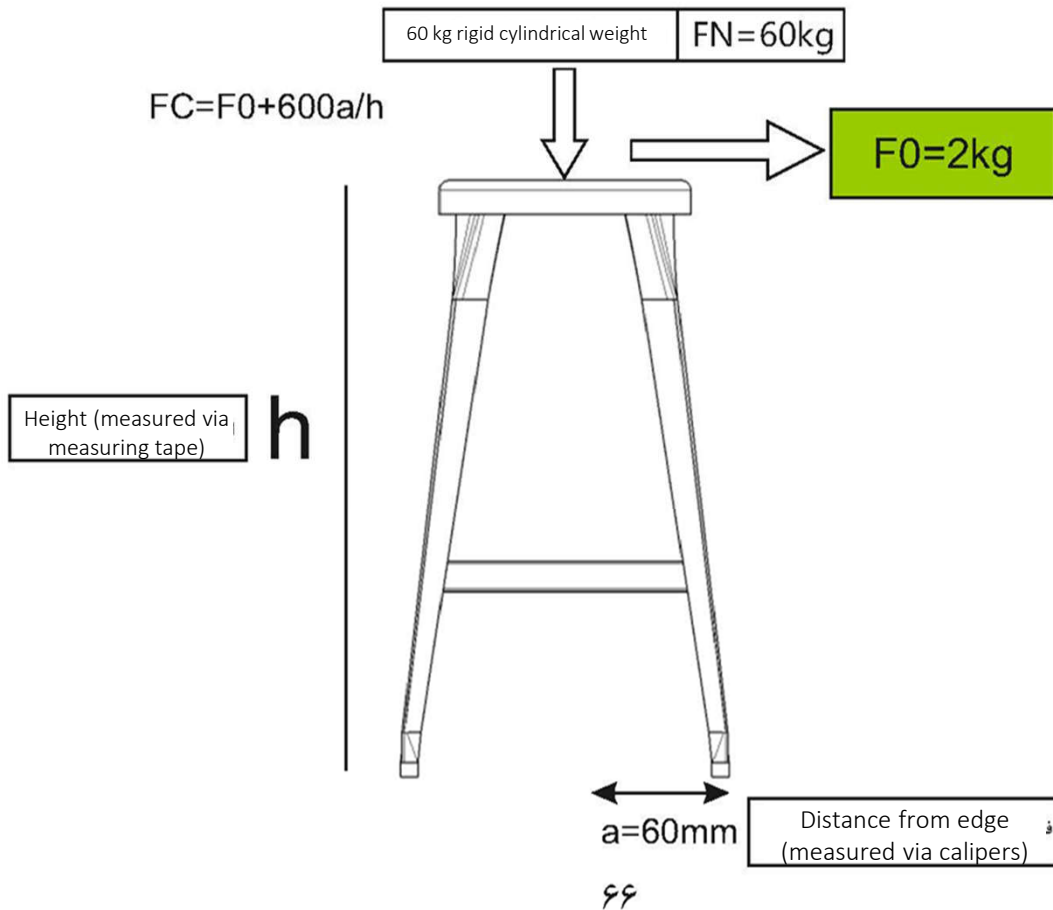

Vertical off-center loading test on the stool seat						
Symbols	Unit	35cm	50cm	60cm	70cm	90cm
F	kg	60	60	60	60	60
a	mm	60	60	60	60	60
Result		No deformation or fracture (stable)	No deformation or fracture (stable)	No deformation or fracture (stable)	No deformation or fracture (stable)	No deformation or fracture (stable)

60 kg rigid cylindrical weight

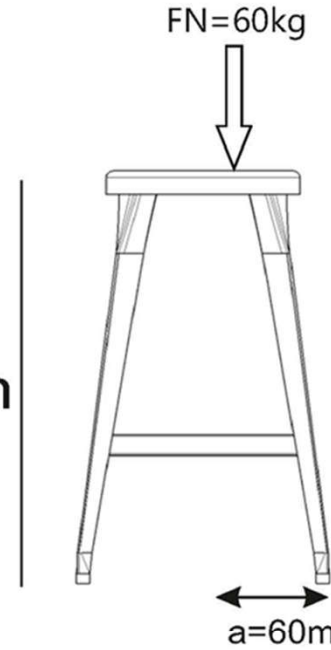

Height (measured via measuring tape)

h

Drop test for the stool

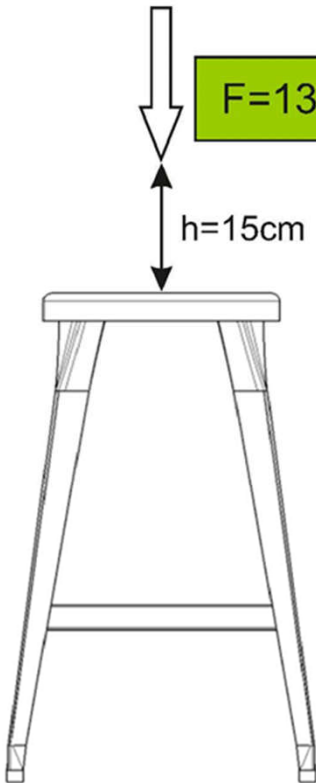

Distance from the edge (measured via calipers)

Drop test on the seat center of the stool						
Test Index	واحد	35cm	50cm	60cm	70cm	90cm
F1	kg	102	102	102	102	102
F2	kg	136	136	136	136	136
h	cm	15	15	15	15	15
Result		No deformation or fracture (stable)	No deformation or fracture (stable)	No deformation or fracture (stable)	No deformation or fracture (stable)	No deformation or fracture (stable)

Salt Spray Test



After the strength and stability tests, the product coatings need to be assessed based on their material and the high-quality oven-cured electrostatic powder paint so that the final product is deserving of the clients.

This test is conducted via the salt spray device in another department of the lab. The final products are exposed to an accelerated corrosion environment according to the respective standards for assessing their coating resistance against corrosion, blistering, and rusting.



Certificates



Structural Products

نهال سان

ایده هایی برای زندگی معاصر



NAHALSAN

ideas for contemporary life

Aluminum Structures

Length (m)	Wt. (kg)
0.5	3
1	4.5
2	7.8
2.5	9
3	10.5
3.5	13
4	15.5
5	18

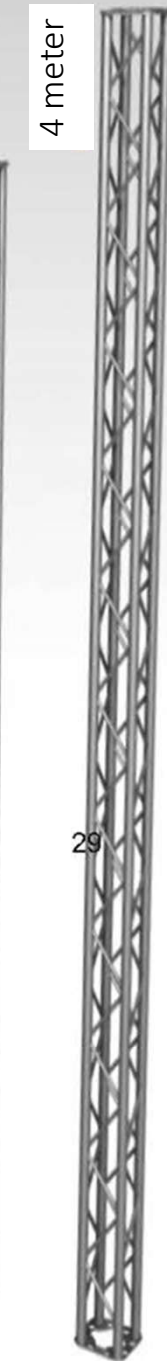
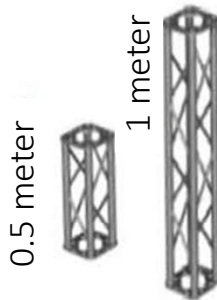
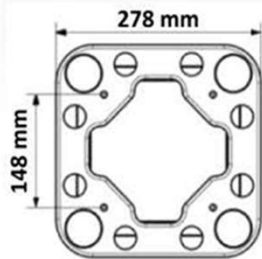

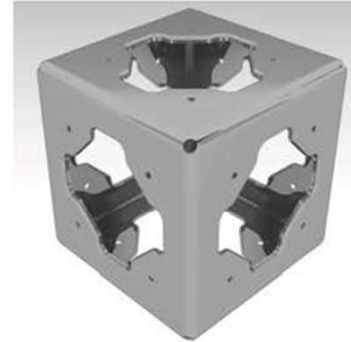
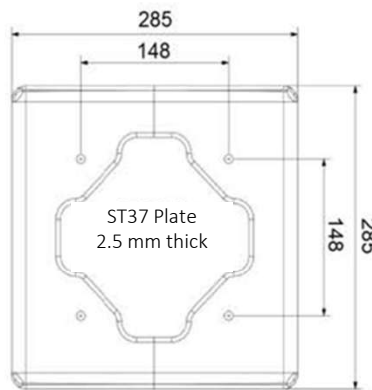
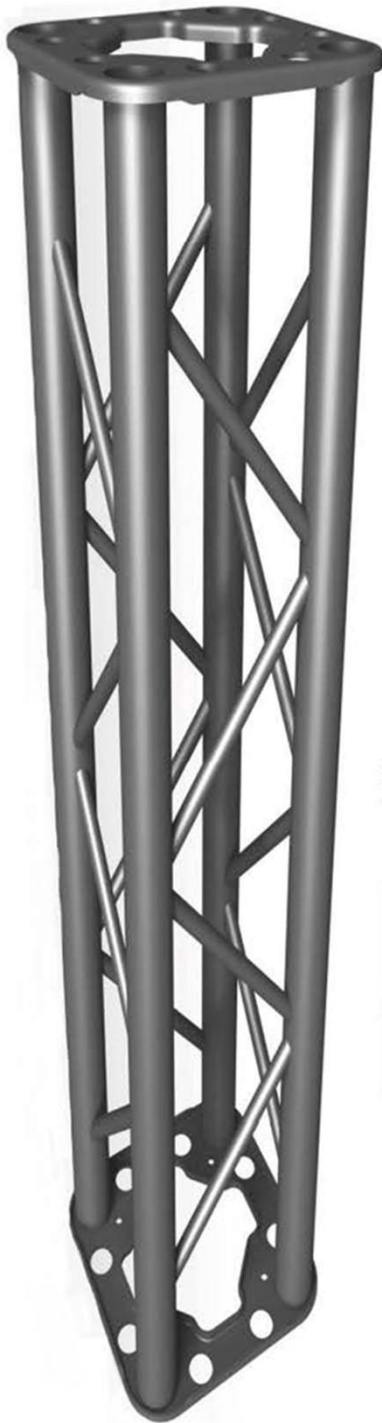

Cubic connectors for vertical attachment of modules

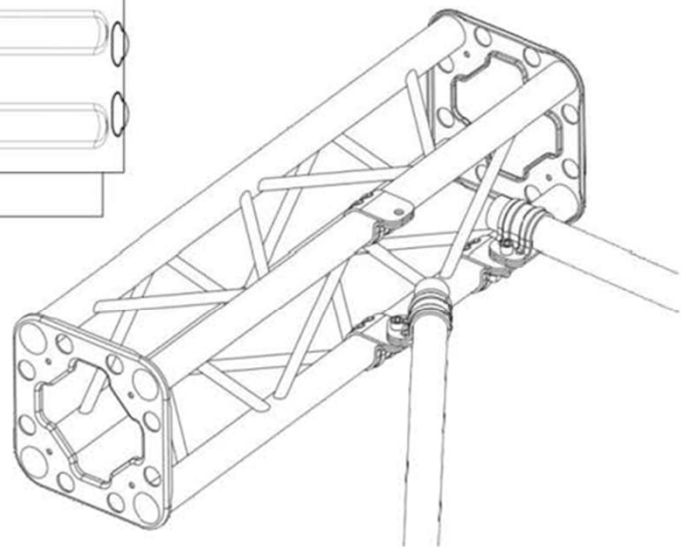
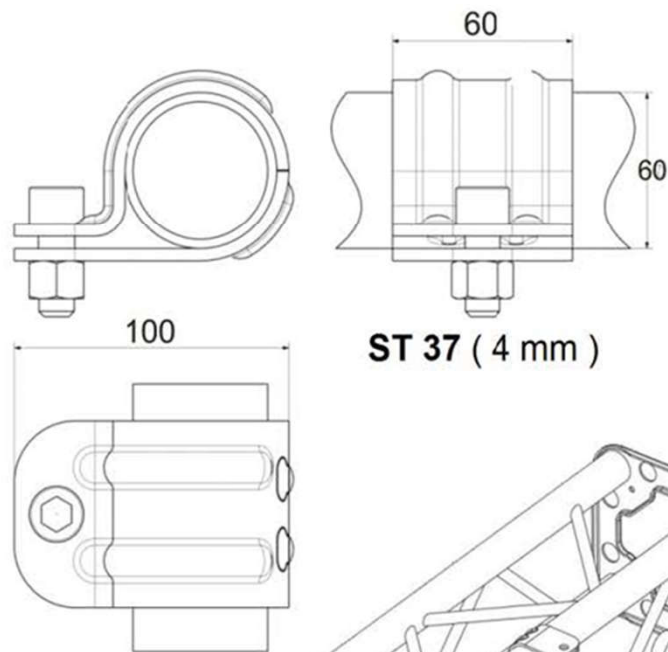

Two-piece fittings for easily connecting the pipes to the structure body allowing for different applications

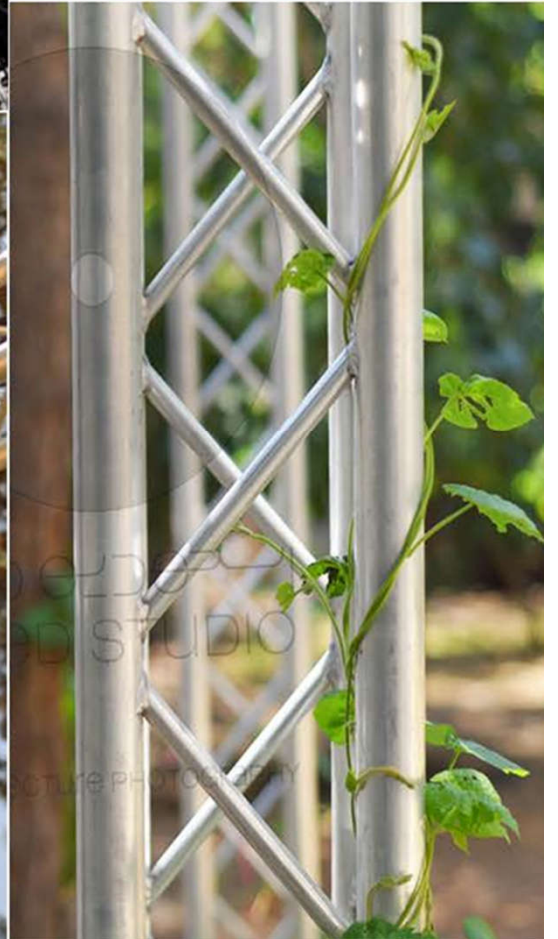
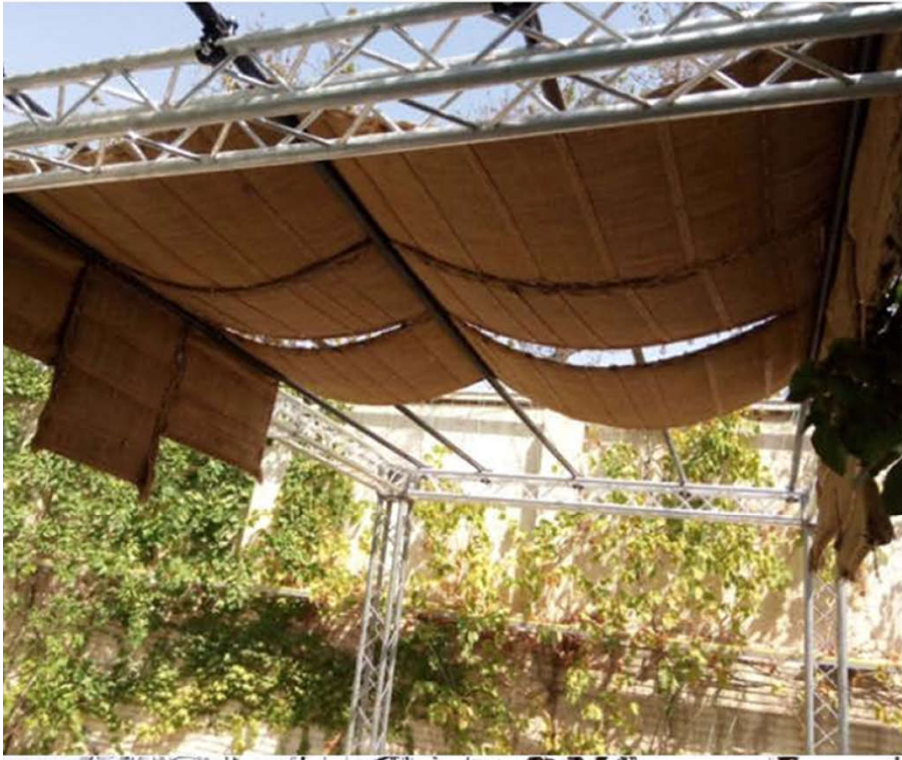

Scaffolding Stairs

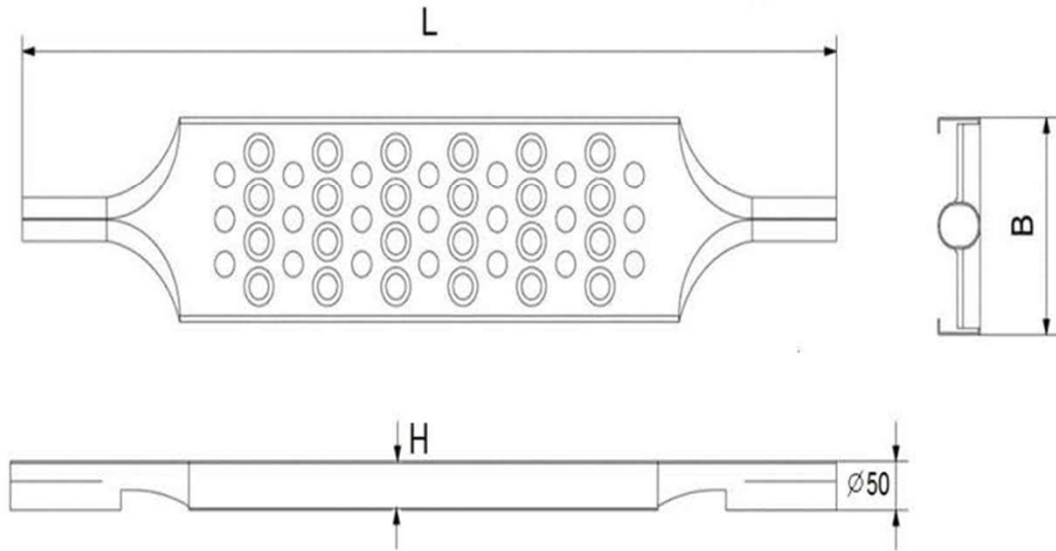

Oven-cured electrostatic powder paint

Plate material: ST37 steel 2.5 mm thick plate

Model 2 (90x22)

Length	Width	Height	Weight
900	220	40	3.9



Model 1 (90x17)

Length	Width	Height	Weight
900	170	40	3.5



Model 3 (200x17)

Length	Width	Height	Weight
2000	170	60	5



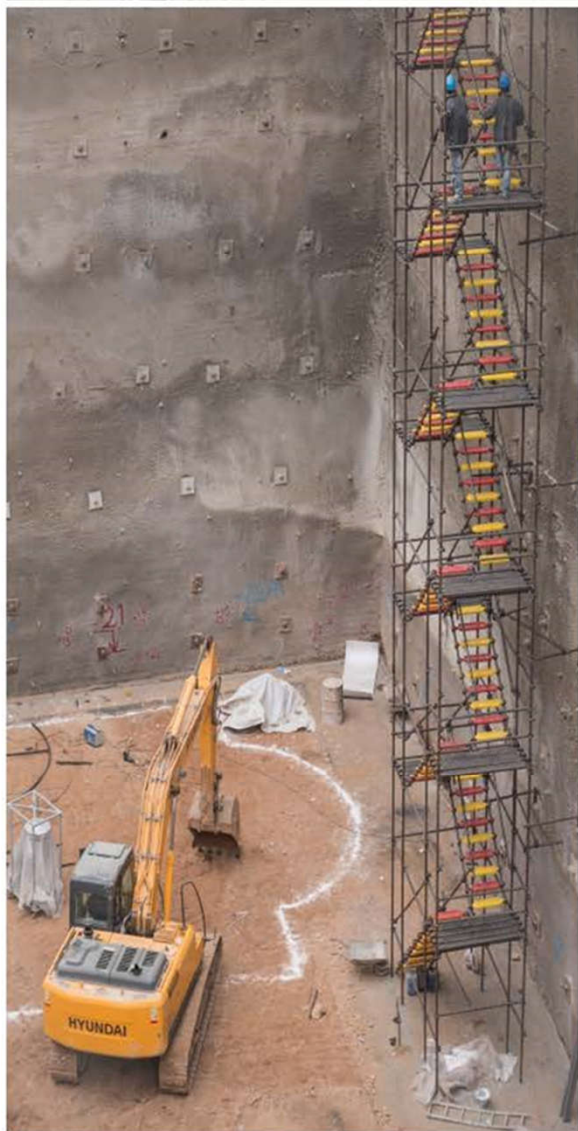
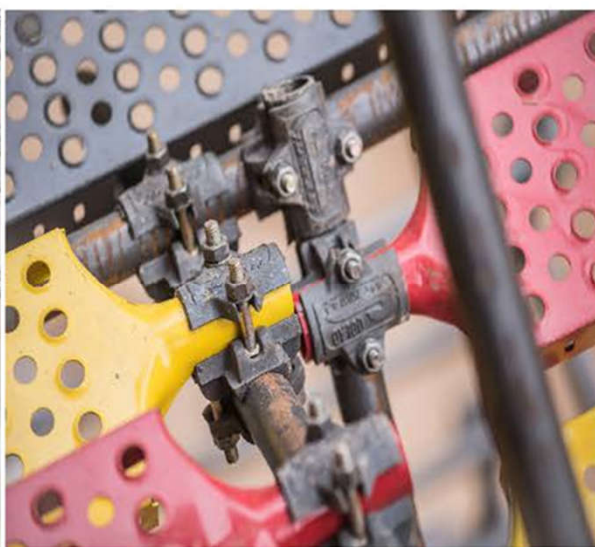

Stair Models

- Available in three models: simple (straight), spiral, and combined shapes
- Made of best-quality plates and material
- Indoors and outdoors application
- ST37 plate (2 mm/2.5 mm thickness)
- Custom stair depths available according to standards, applications, or client preference
- Precise 3D design and display to the client before manufacture
- Custom component paint according to the place and client preference
- Unique, beautiful design
- No welding
- Oven-cured electrostatic paint
- Safe against slipping and sliding

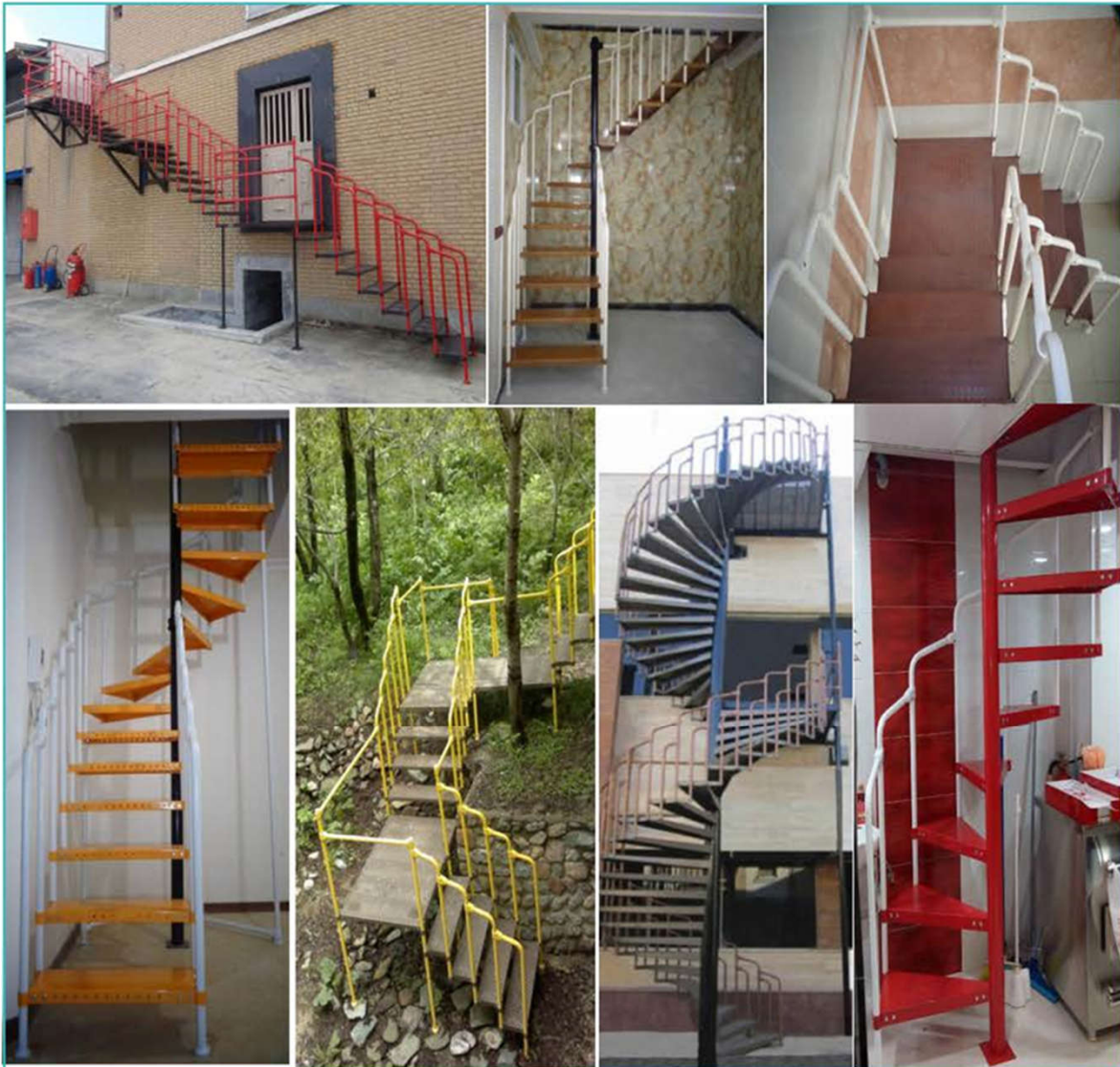

Straight staircase

Length: 58 to 190 cm

Width: 22 to 30 cm

Height: 40 to 60 cm

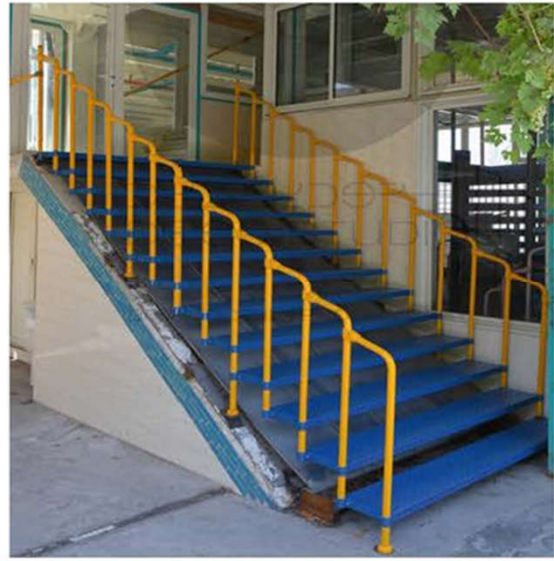
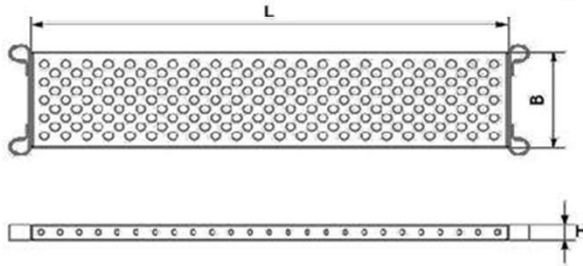

Compact

Clockwise and counter-clockwise directions

Beautiful facade

Spiral staircase

Diameter: 1 to 3 m

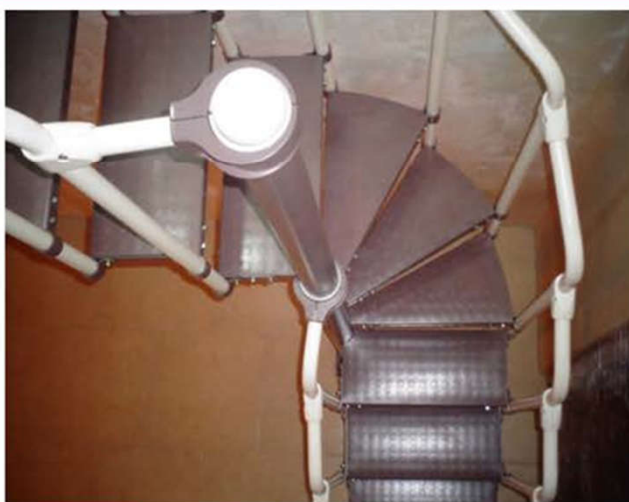
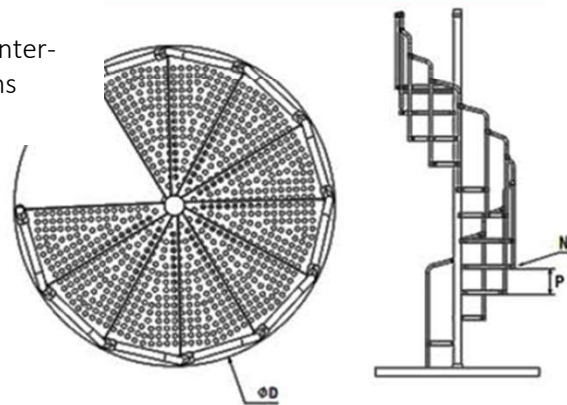

Combined shapes staircase

A combination of circular and straight staircases mixing their attributes, custom-designed for different requirements and locations.

NAHALSAN

ideas for contemporary life



www.Nahalsan.com



@Nahalsan



@Nahalsan



021-65513646
09391600934

Plant Phone: (98) 2165533200-2

Fax: (98) 2165533203

Post code: 3354432917

Address: No. 10, 2nd St., Shahid Siri (Derakhti) St., Next to Pasargad Fuel Station, between Phases 1 and 2 of Andishe Residential Complex, Shahriar City, Tehran Province, Iran

